

Corporation obtaining approval, the name of its representative, and the address of its main office

Applicant

Name: Suntory Limited

Nobutada Saji, President

Address: 2-1-40 Dojimahama, Kita-ku, Osaka City,
Osaka

Approved Type 1 Use Regulation

Name of the Type of Living Modified Organism	Rose Variety with Modified Flavonoid Biosynthesis Pathway (<i>F3'5'H</i> , <i>5AT</i> , <i>Rosa hybrida</i>) (WKS82/130-4-1, OECD UI: IFD-52401-4)
Content of the Type 1 Use of Living Modified Organism	Appreciation, cultivation, storage, transportation and disposal of cut flowers, and other acts incidental to them
Method of the Type 1 Use of Living Modified Organism	—

Outline of the Biological Diversity Risk Assessment Report

I. Information collected prior to assessing Adverse Effect on Biological Diversity

1. Information concerning a recipient organism or the species to which the recipient organism belongs

(1) Taxonomical position and state of distribution in natural environment

(i) English name and Scientific name

English name: Rose

Scientific name: *Rosa hybrida*

(ii) Name of variety of the recipient organism or name of line

Name of rose cultivar used as the recipient organism is WKS82 (Registration of variety under application, Date of application filing: November 22, 2004, Application No.: 17636, Applicant: Keisei Rose Nurseries, Inc.). Cultivars of rose are divided into Hybrid Tea, Floribunda, Polyantha and other groups, and the WKS82 belongs to the Hybrid Tea group and blooms large purple-red flowers all the year round.

(iii) Wild-growing areas under natural environment in Japan and abroad

Plants of rose family are classified into approx. 100 genera and 3,000 species, which are widely distributed over the world and most diversified in the north temperate latitudes and subtropics (Tsukamoto, 1989¹). Plants of the genus *Rosa* are widely distributed in the northern hemisphere subtropics to Frigid Zone ranging from Ethiopia in the south to Siberia in the north. Rose cultivars are inter-specific hybrids developed by artificial crossing between the wild species of the genus *Rosa*. The genus *Rosa* is divided into four subgenera and the rose subgenera are important for horticultural applications. A total of 120 species of plants of the genus *Rosa* are growing across the world, 10 in Europe and Africa, 93 in Asia (15 species of them are also distributed in the other continents), 20 in the American Continent (two species of them are also growing in Asia), and 11 in Japan (including two to three variant species) (Tsukamoto, 1989¹). The species of *Rosa* subgenera are widely distributed over the both continents, new and old, those of the *Hulthemia* subgenera are distributed from Western Asia to Central Asia, those of the *Platyrhodon* subgenera are spread in China and Japan, and those of the *Hesperhodos* subgenera are distributed in the limited range of areas in the North America including Arizona, Texas and Baja California (a peninsula extending south and north on the west coast of North American Continent and belonging to the territory of the United Mexican States), and a great deal of species have been differentiated to accommodate a very wide variety of environments from forests to seashores (Ueda, 2002²). Those wild species have been cultivated as they are that are worth of appreciating otherwise intended for medicinal use, flavors and rootstocks for grafting. However, it is considered that current rose cultivars are inter-specific hybrids developed based on the crossing between around eight wild species (*R. multiflora* Thunb. ex Murray (*Rosa multiflora*), *R. wichuraiana* Crép. (*Rosa wichuraiana*), *R. rugosa* Thunb. ex Murray (*Rosa rugosa*), *R. gallica* L., *R.*

foetida Herrm., *R. moschata* Herrm., *R. gigantea* Collett, *R. chinensis* Jacq.f. *spontanea* Rehd.et Wils., etc.) (Tsukamoto, 1989¹).

(2) History and present state of Use

(i) History of Type 1 Use in Japan and abroad

Current rose cultivars have been developed in most cases by crossing between garden varieties. Since the introduction of artificial crossing in 19th century, as many as 27,000 garden varieties have been developed up to date. The currently growing garden varieties are estimated 2,000 to 3,000 in number, a limited number of which is, though, cultivated worldwide. In Japan, 400 to 500 garden varieties are commercially available (Sakanishi, 1989³).

It was around 1917 when the American style production of roses for cut flowers in greenhouses in Japan was launched, though it was on a smaller scale, where American Beauty, Killarney and other varieties brought in from the U.S. were reportedly cultivated. In the Kanto Region, greenhouse cultivation was started around 1918 to 1919 and then, commercial cultivation of roses under glass became popular around 1921 with the scale expansion driven. In the late 1945, cultivation in vinyl-covered greenhouses was put into practical use, which contributed to significant reduction in the initial investment cost compared to glass greenhouses and facilitated the adoption of rose cultivation. In 1963, gravel culture was transferred for hydroponics (soil-less culture/nutrient solution culture) in greenhouses, which evolved toward Rockwool culture in 1985. At present, production of roses for cut flowers is expanded into a nearly nationwide scale, and the cut flowers of roses are found third-ranked wholesale amount according to FY 2005 Outline of Survey on Flowers Wholesale Markets (announced May 24, 2006 by Statistics Department, Minister's Secretariat, Ministry of Agriculture, Forestry and Fisheries). The number of rose cultivars in circulation in the market exceeds 200 (Hayashi, 2002⁴).

Outside the Japan, rose cultivation was reportedly originated in the Near and Middle East and China where civilizations became earlier advanced and then, the roses underwent further development in Europe. Roses are thus considered as representative flowers developed based on the fusion of Eastern and Western flower cultures in Europe (Sakanishi, 1989³). Up to the 18th century in Europe, those varieties had been mainly cultivated which were developed by crossing between wild growing original species and thus, the ecological differentiation remained in a limited range. However, driven by the introduction of Asian original species into Europe at the end of 18th century, artificial crossing between European and Asian original species became prevailing since 19th century, and a great deal of varieties have been developed with various ecological characters in terms of perpetual and flowering properties in addition to flower color and flower type (Tsurushima, 1979⁵).

(ii) Main cultivating areas, cultivating methods, state of physical distribution and uses

Roses for cut flowers are produced nearly in all parts of Japan. According to FY 2005 Planted (Harvested) Area, Production and Shipment of Flowers (announced

May 24, 2006 by Statistics Department, Minister's Secretariat, Ministry of Agriculture, Forestry and Fisheries), the major production area is the Tokai Region, including Aichi Prefecture and Shizuoka Prefecture, which accounts for approx. 30% of the total shipment throughout the country. In addition, the Tokai Region contains the largest number of rose producing farmers, accounting for approx. 20% of the total in the whole country.

The methods of cultivation are mainly based on soil culture and Rockwool culture. The flower buds differentiate independently of temperature and day length, though the subsequent growth greatly depends on light intensity and temperature and then, the following four types of cultivation are adopted in consideration of regional weather conditions and geographic features to allow the year-round shipment to the market. The cultivation types include 1) cutting of flowers chiefly in winter which consists of planting in early spring, harvesting five to seven times between early autumn to the next year mid- to late June, pruning for reducing the tree height and pinching, and harvesting restarting from September, 2) setting dormant at midwinter which consists of resting with heating interrupted for exposure to low temperatures, pruning and restart of heating, and gathering of flowers between March and April, 3) cutting of flowers in summer which consists of gathering of flowers from early summer to early winter without any heating in simple facilities, and 4) year-round cutting of flowers which consists of gathering of flowers all the year around. The typical cultivation type in Japan is the cutting of flowers in winter (Okawa, 1989⁶), Okawa, 2002⁷). Overall yield per plant varies with cultivation method and variety cultivated, though it is typically 10 to 50 cut flower roses.

According to the statistics based on FY 2005 Planted (Harvested) Area, Production and Shipment of Flowers, the annual shipment of cut flowers of rose in 2005 in Japan was approx. 390 million pieces, which were all produced based on protected cultivation.

On the other hand, outside Japan, Netherlands, Spain, Italy, the U.S., and France are richly cultivated with roses for cut flowers (Okawa, 1989⁶). In addition, it is known that Israel and African countries export the cut flowers of rose to the world markets through the Netherlands market and that the South and Central America countries increase the export to the U.S. market. The African countries and South and Central America countries are located in the high-altitude cool region in the tropic zone and then, increase the production year by year, making full use of the advantages of consistent temperatures throughout the year, abundance of labor force, low wages, simplicity of facility, and inexpensive land prices. Among the neighboring countries of Japan, Korea is putting a great deal of effort into the export on a government-wide scale by rapidly increasing the modern greenhouses based on government subsidy. In addition, India has just started exporting to Europe, and it directs the export to Japan in some seasons for the lower prices (Kano, 2002⁸). Based on the results of FY 2005 Survey on Flower Wholesale Markets (announced May 24, 2006 by Statistics Department, Minister's Secretariat, Ministry of Agriculture, Forestry and Fisheries), the import volume of cut flowers of rose from overseas to Japan is 54.93 million (97% compared to the previous year), accounting for 12.6% of the domestic distribution volume in Japan.

Rose cultivars are used mostly for ornamental purposes, though they may be additionally processed into fragrance, potpourri and preserves (Kondo, 2004⁹).

(3) Physiological and ecological properties

(i) Basic properties

Wild roses are deciduous or evergreen shrub, featuring standing or climbing tree form while some species creep on the ground. The stems and branches have thorns in most species. The leaves are alternate odd-pinnate compound leaves with the partly coalescing stipules into petioles. The leaflets have serrations. The flowers open singly at shoot apex otherwise corymbose or paniculate, ranging from the minimum number of three to the maximum number of around 30. The color of flowers includes white, yellow and crimson. The basic number of petals is five, though there are many double-petaled flowers with the petaled stamen (Tsukamoto, 1989¹, Nomura, 2004¹⁰).

Rose cultivars are roughly classified into Hybrid Tea group, Floribunda group, and Polyantha group according to the tree form and the flower size. The characteristics of individual groups are described below.

- Hybrid Tea group: It includes ever-flowering large-flowered varieties. The Hybrid Tea roses bear one to a few flowers on each branch with the diameter of flower exceeding 10 cm. Normally, the flowers are double-petaled. The tree form is standing or shrubby bush-shaped, and the tree height ranges from 90 cm up to around 1.8 m.
- Floribunda group: It includes ever-flowering medium-flowered varieties. The Floribunda roses bear a few to a dozen or so flowers in clusters on each branch with the diameter of flower ranging from 5 to 10 cm. The tree form is standing or shrubby bush-shaped, and the tree height ranges from 70 cm up to around 1.2 m.
- Polyantha group: It includes ever-flowering small-flowered varieties. The Polyantha roses bear multiple flowers in clusters with the diameter of flower ranging from 3 to 6 cm. The tree form is mainly tree-like, though some varieties are climbing or semi-climbing form. The tree height ranges from 60 cm to around 1.0 m (Kondo, 2004⁹, Nomura, 2004¹⁰).

The recipient organism WKS82 is an ever-flowering cultivar belonging to Hybrid Tea group, bearing the center-elevated sword-shaped petal flowers with the diameter of around 11 cm and the color of purple-red. In addition, the tree form has upright habit. The WKS82 was developed in 1993 in Japan by crossing Madam Biore (Hybrid Tea group cultivar) and Silver Star (Hybrid Tea group cultivar).

(ii) Environmental conditions allowing inhabiting or growth

Roses grow well and bear flowers in the temperature range from 20 to 25°C, and they can overwinter and survive the summer in the natural condition in Japan. At temperatures above 30°C, the stems and leaves do not grow well, resulting in smaller flowers. In addition, at temperatures below -5°C, roses are reportedly

susceptible to freezing damage. It has been said that the most important environmental factor governing the growth of roses is the effects of light. It is important to select an appropriate place which is well-ventilated and exposed to morning sunlight at least for five hours. Soil aeration and drainage is essential and then, ill-drained areas require installation of drainage pipes and softening of soils by adding sand and/or persistent organic substances (peat-moss, bark manure, etc.) before planting. For the acidity of soil, slightly acid soil at pH 5 to 6 is reportedly optimal.

As typical effects of temperatures at stages of growth and flowering on the morphology, it is known from the cultivation of Ma Perkins belonging to Floribunda group at temperatures of 11.1, 16.6, 22.2, 27.7 and 33.3°C that the diameter of flower became largest at 16.6 and 22.2°C, the length of pedal and the number of pedals were largest at 16.6°C, and the number of pedals at high temperatures of 27.7 and 33.3°C became five, the basic number of pedals for the original species of rose.

Strong light can cause leaf burn, fading flower color, flower blurring and other deterioration in quality and thus, light shielding is required also when exposed to larger amount of light not only in summer season. The light shielding may be needed roughly from April to September by controlling the light intensity transmitted to 70,000 to 80,000 lux (Sakanishi, 1989³⁾, Sakai, 2002¹¹⁾).

(iii) Predacity or parasitism

(iv) Mode of propagation or reproduction

1) Shedding habit, mode of dispersion, dormancy and longevity of the seed

The seeds of roses are enclosed in pericarp (endocarp, mesocarp, epicarp) independently without adhesion to each other, and several seeds are covered with a receptacle (also known as torus) to form a fruit called a hip. The hips remain on the plants for a long period even after ripening (Gudin, 2003¹²⁾). This helps eliminate the shedding of the seeds from plant body and then, there is no or least possibility of dropping hips.

The rose seeds have dormancy and the degree of dormancy significantly varies among the species and the varieties (Gudin, 2003¹²⁾).

The longevity of rose seeds varies greatly among the species and the varieties. It was confirmed that the seeds of wild species kept the germinating capacity at least for four years when they were stored in a hermetically sealed vessel at 1 to 4°C under dry condition (Gudin, 2003¹²⁾).

For garden varieties, seed propagation is practicable, though it requires breaking of dormancy based on low-temperature treatment or other proper means, so there is no or extremely low possibility of seed propagation under natural condition.

- 2) Mode of vegetation (outgrowth, tuber, tuberous root, runner, etc.) and the property of germination from any tissue or organ which could regenerate the plant body under natural condition

Wild rose species could proliferate under natural conditions through seed propagation otherwise propagation by suckers (shoots growing from the rootstock and extending horizontally underground) which is seen in some species such as *Rosa rugosa* (*R. rugosa* Thunb. ex Murray) and *Rosa multiflora* (*R. multiflora* Thunb. ex Murray). In contrast, in rose cultivars, propagation by suckers never occurs. Artificially vegetative propagation through herbaceous cutting or grafting is practicable.

- 3) The degree of autogamy and allogamy, presence or absence of self-incompatibility, possibility of crossing with wild relative, and the degree of apomixes causing characteristics, if present

- a. The degree of autogamy and allogamy

For breeding of rose cultivars, autogamy or allogamy is performed in general and so, rose cultivars are considered to have the properties of autogamy and allogamy, which are, though, referred to only in a limited number of scientific literatures.

For the Hybrid Tea group varieties White Weekend and White Masterpiece, there is a report that their inbred posterity has been developed based on artificial crossing (De Vries and Dubois, 1978¹³).

In addition, also for the Polyantha group varieties Meinadentel, New Penny, Kathleen Zeimet, The Fairy, Marie Pavic, Yvonne Rabier, and Kathleen, there is a report that their inbred posterity has been developed by artificial crossing (Dubois and De Vries, 1987¹⁴).

In the experiments on the crossing rate through several repeated crossings, it was reported that artificial crossing of Hybrid Tea cultivar Sonia with a different Hybrid Tea cultivar Ilona resulted in around 50% of rate of fruit bearing in once pollination though the rate of fruit bearing increased to nearly 90% through five times of pollination every other day (De Vries and Dubois, 1983¹⁵).

Based on the above understanding, it is known that rose cultivars exhibit autogamy and allogamy though greatly varying among the cultivars. The WKS82 used as the recipient organism for this recombinant plant exhibits autogamy and allogamy.

- b. Presence or absence of self-incompatibility

As mentioned in the previous section, there are some reports that rose cultivars could produce inbred posterity through artificial self-pollination though varying greatly among the species and cultivars and thus, rose

cultivars are considered not to represent self-incompatibility. The WKS82 used as the recipient organism for this recombinant plant does not represent any self-incompatibility.

As a result of artificial crossing using 48 different wild rose species, it was indicated that the rate of fruit bearing varies from 0% (28 species) to 100% (one species). For example, the rate of fruit bearing was found 0% for *Rosa multiflora* Thunberg var. *adenochaeta* (Koidzumi) Ohwi (*R. multiflora* var. *adenochaeta* (Koidz.) Makino), and *Rosa wichuraiana* (*R. wichuraiana* Crép.) and 13.3% for *Rosa rugosa* Thunb f. *alba* (*R. rugosa* Thunb. ex Murray f. *alba* (Ware) Rehder). In addition, it is reported that hyperploid species have self-compatibility (Ueda and Akimoto, 2001¹⁶). *Rosa rugosa* (*R. rugosa* Thunb. ex Murray) and other wild species represent self-incompatibility, which is considered gametophytic self-incompatibility, and the pollens representing self-incompatibility induce the inhibition of pollen tube growth after pollination, thus failing to fertilize (Jacob and Ferrero, 2003¹⁷).

c. Crossability with wild relative

(a) Wild relatives indigenous to Japan

Wild relatives indigenous to Japan include ten (10) species, *Rosa multiflora* Thunb. ex Murray, *Rosa wichuraiana* Crép., *Rosa rugosa* Thunb. ex Murray, *Rosa acicularis* Lindl., *Rosa marretii* Lév., *Rosa luciae* Franch. et Rochebr., *Rosa sambucina* Koidz., *Rosa bracteata* Wendl., *Rosa laevigata* Michx., and *Rosa roxburghii* Tratt. var. *hirtula* (Regel) Rehd. et Wils., and six (6) variant species, *Rosa acicularis* var. *nipponensis* (Crép.) Koehne., *Rosa multiflora* var. *adenochaeta* (Koidz.) Makino, *Rosa luciae* var. *hakonensis* Franch. et Sav., *Rosa luciae* var. *fujisanensis* Makino, *Rosa luciae* var. *onoei* (Makino) Momiyama, and *Rosa luciae* var. *paniculgera* (Makino) Momiyama (Ueda, 2002²). Among these, the wild species indigenous to Japan, which were used for production of rose cultivars, are *Rosa multiflora* Thunb. ex Murray, *Rosa wichuraiana* Crép., and *Rosa rugosa* Thunb. ex Murray (Gudin, 2000¹⁸), Hurst, 1941a¹⁹), Hurst, 1941b²⁰), Hurst, 1941c²¹), Wylie, 1954²²), Wylie, 1955a²³), Wylie, 1955b²⁴). The natural wild growth areas and the environments in which they grow are summarized below.

- *R. multiflora* Thunb. Ex Murray: Distributed from Hokkaido to Kyushu in Japan and also in Korea. Relatively climbing shrub seen normally in flatlands and highlands. Seven to nine leaflets with the stipules torn into pieces like feather, forming as if fine-toothed comb. Bears many panicle white flowers. Flowers open May to June. In Japan, the *R. multiflora* has been mainly used for rootstock to develop excellent selected lines. The cluster-flowering property of Floribunda group rose cultivars was transferred from the *R. multiflora*.

- *R. wichuraiana* Crép. : Distributed in Mainland, Shikoku, Kyushu and Okinawa in Japan, Korea, Taiwan, and China. Favors sun-filled places, grows in seaside districts to waste land, grassland, and highlands. The stems are long and they creep. Leaflets are five to nine, thick and glossy. Bears several white flowers at the tip of each branch. Flowering period is June to July, later compared to related species. The trait of long growing branches of climbing rose is derived from this species.
- *R. rugosa* Thunb. ex Murray: Grows in sandy soil on the seashore. Widely distributed in the temperate latitudes to Frigid Zone including Hokkaido and Mainland (northward from Ibaraki Prefecture in the Pacific seaboard and northward from Shimane Prefecture along the Sea of Japan) in Japan and East Asia (Korea, northern China and parts north). Thorns and stings grow thick on the entire branches. *Rosa rugosa* propagates by suckers and grows in crowd. The leaves are prominently rugose, which stands for the name of species "rugosa". One to three large flowers come out at the tip of each branch, showing purple-red color with fragrance. The flowering period is relatively longer from May to July. Some variant species open white color flowers. It features resistance to both cold and disease, thus being of utility value for breeding and in fact, cold-resistant cultivars (Hybrid Rugosa) have been developed.
- *R. acicularis* Lindl.: Very widely distributed in Hokkaido and Mainland (high mountains in the Chubu and Tohoku Regions) in Japan, Sakhalin, Korea, northeastern region of China, Siberia, Northern Europe, and North America, and available in the form of tetraploid to octoploid. On the branches, thorns and stings are dense, and the number of leaflets ranges from five to seven. Flowers open singly at the tip of short branches, showing the crimson color of flowers. The flowering period is June to July.
- *R. marretii* Lév.: Distributed in Hokkaido and Mainland (Nagano Prefecture) in Japan, Sakhalin, Korea, China, and Northeastern and Eastern Siberia. The leaflet is seven to nine in an ellipsoid shape. The undersurface of leaf turns lighter in color, taking on a white tinge. The flowers are crimson in color, coming out in the period from June to July.
- *R. luciae* Franch. et Rochebr.: Distributed in Kanto and Tokai Region (Toyokawa in Aichi Prefecture and eastward) in Japan. Branches have hook-shaped thorns, climbing by leaning against neighboring objects. The leaflet is five to seven in number with the surface having a shine. At the tip of branches, white color flowers open in the paniculate inflorescence. The flowering period is May to June.
- *R. sambucina* Koidz.: Distributed in Mainland (Aichi Prefecture

and westward), Shikoku, and Kyushu in Japan. Large shrub climbing high by leaning against neighboring objects with the strong hook-shaped thorns. The leaflet is five (or seven in rare cases) in number, growing up to form a large ellipsoid shape with the narrow and sharp-pointed tips. Many large white flowers come out in the corymb inflorescence. The flowering period is May to June.

- *R. bracteata* Wendl.: Distributed in Yaeyama Islands in Japan, Taiwan, and the southern part of China. Branches have lint and lean against neighboring objects, creeping or standing upright. The leaflet is five to nine in number, thick and glossy. Large white flowers open singly at the tip of each branch. The flowering period is long from February to August. The flower pattern contains several bracts, and the bracts and sepals have lint.
- *R. laevigata* Michx.: Native to the southern part of China. Growing wild also in Japan in Southern Wakayama Prefecture, Shikoku, and Kyushu. This species was first reported based on the wild growing plants discovered in the southern part of North America. The stem has hook-shaped thorns, and the plant is climbing, presenting very vigorous growth. The leaflet is three (or five in rare cases) in number, forming an ellipsoid with the sharp-pointed tip and having a shine. The species is evergreen. Large white flowers open singly at the tip of small branches. The flowering period is May. The pedicel and calyx tube have thin thorns.
- *R. roxburghii* Tratt. var. *hirtula* (Regel) Rehd. et Wils.: Distributed in the Fuji and Hakone Districts in Japan. The mother species and related cultivar "f. *normalis* Rehd. et Wils." grow also in China. It is a tree-like small high shrub, growing up to a maximum of a few meters. Old tree barks fall. The leaflet is 9 to 15, and the compound leaf looks like *zanthoxylum piperitum* and then this species is named *R. roxburghii* Tratt. var. *hirtula* (Regel) Rehd. et Wils.. Large salmon pink flowers come out singly at the tip of each branch. The calyx tube has strong thorns all over the surface. The flowering period is June. The double-flowered cultivated species are known as *R. roxburghii*, which were formerly brought over from China. It is listed in the classification II of endangered species (species whose survival is increasingly endangered) in the Red Data Book published in 2000.
- *R. acicularis* var. *nipponensis* (Crép.) Koehne.: The *R. acicularis* var. *nipponensis* (Crép.) Koehne. [var. *nipponensis* (Crép.) Koehne.] , a variant species of *R. acicularis*, has more leaflets (7 to 9) compared to the mother species and smaller in the size of the entire plant. It is distributed in Mainland (Chubu Region and northward) and Shikoku in Japan.

- *R. multiflora* var. *adenochaeta* (Koidz.) Makino: A variant species of *R. multiflora*. Grows wild in the southern Kyushu Region, featuring a large plant size. The leaves have a shine, and flowers are large, opening in clusters in the paniculate inflorescence and showing salmon pink in color. The inflorescence and flower pattern feature many glandular trichomes.
- *R. luciae* var. *hakonensis* Franch. et Sav.: A variant species of *R. luciae* Franch. et Rochebr. Distributed in Mainland (Kanto Region and westward), Shikoku, and Kyushu in Japan. Differently from the mother species and other variant species, it opens flowers singly at the tip of branches (two to three flowers in the umbellate inflorescence in rare cases).
- *R. luciae* var. *fujisanensis* Makino: A variant species of *R. luciae* Franch. et Rochebr. Distributed in Fuji and Hakone Districts, Kii Peninsula, and Shikoku in Japan. It is generally large in size and the trunk also grows thick. It grows at higher altitudes compared to the other variant species, and opens flowers later in June to July.
- *R. luciae* var. *onoei* (Makino) Momiyama: A variant species of *R. luciae* Franch. et Rochebr. Distributed in Mainland (Kii Peninsula and southward), Shikoku, and Kyushu in Japan. The flowers and hips are small.
- *R. luciae* var. *paniculgera* (Makino) Momiyama: A variant species of *R. luciae* Franch. et Rochebr.. Distributed in Mainland (Hokuriku, Kinki, Chugoku), northern part of Shikoku, and northern part of Kyushu in Japan. Multiple flowers open in the paniculate inflorescence (Ueda, 2002²⁾).

(b) Crossability with wild relatives under natural conditions

Regarding the crossability between rose cultivars and wild species in natural conditions in Japan, there is a report on the study conducted in 2005 in which seeds were collected at random from the wild species growing wild in the environment where rose cultivars were raised in the neighbor and from the wild species adjacent to which rose cultivars were raised, the collected seeds were sown to obtain seedlings, and the seedlings were examined for crossability with rose cultivars (Nakamura et al., 2007²⁵⁾). According to the report, as a result of analysis on a total of approx. 1,300 individuals of seedlings obtained from the seeds collected randomly from a total of five sites in Chiba Prefecture, Okayama Prefecture (2 sites), Gifu Prefecture, and Hokkaido, no crossing between rose cultivars and wild species was found existent. Consequently, it is considered that there is no or extremely low crossability between wild species and rose cultivars under natural conditions.

Regarding the crossability with wild species under natural conditions,

opinions were obtained from the persons with specialized knowledge and experiences.

[Professor Hirokazu Fukui at Faculty of Applied Biological Sciences, Gifu University (an outside member of Safe Practice Committee on Utilization of Recombinant Organisms in the Misaki isolated field of Nihon-Shokusei Co.)]

Most wild species are diploid, while rose cultivars are tetraploid. It cannot be denied absolutely that artificial crossing could produce hybrid seeds. Even in such case, however, hybrid individuals would be triploid and then, when they come into flower, the reduction division of reproductive organs (pollens, egg cells) become abnormal and they fail to possess normal fertility. As a result, the crossability of the next generation is considered extremely low.

In addition, wild species and rose cultivars differ from each other in the species and then, any inter-specific hybrids would suffer poor growth by nature. In practice, it has been confirmed at the Fukui Laboratory of Faculty of Applied Biological Sciences, Gifu University, that when wild species are polyploidized to produce the tetraploid and artificially cross it with rose cultivars (tetraploid), the hybrid cultivars grow very poorly (unpublished data). This suggests that the hybrid posterity between diploid wild species and tetraploid rose cultivars is estimated to grow poorly.

In actuality, a rose garden in Gifu Prefecture deals in crossing and breeding of rose cultivars and production of rootstock of *R. multiflora*. In the open fields, seeds are collected by bringing the *R. multiflora* (cultivar K2) into flower followed by natural crossing, and, in the facilities, cultivated species are crossed and bred. However, there has been no case in the rose garden in which *R. multiflora* was crossed with rose cultivars.

In addition, despite the facts that approximately 500 million cut flowers of rose are produced and marketed every year in Japan and that there are many rose gardens in all parts of Japan, there is no report that rose cultivars have gone wild under natural conditions.

Based on the above understanding, it is considered unlikely that rose cultivars would be crossed with wild species under typical natural conditions in Japan. It cannot be denied absolutely that artificial crossing might produce hybrids with a low probability, though the possibility of normal growth of the hybrid individuals is low and the possibility of having normal fertility is also considered low.

[Professor Yoshihiro Ueda at Gifu International Academy of Horticulture]

Wild rose species growing in natural conditions in Japan are not

located in the vicinity of rose cultivars in general. Even if they are located close to rose cultivars, it is very unlikely that insects would convey the pollens of rose cultivars to wild species. If the pollens of rose cultivars are transmitted to wild species, generally the pollens of other neighboring wild species are also conveyed. In this case, wild species preferentially select the pollens derived from the wild species and use them for fertilization, so the probability of fertilization of rose cultivar pollens with egg cells of wild species is considered extremely low.

[Associate Professor Shogo Matsumoto at Faculty of Education, Gifu University]

In the field in Gifu University, rose cultivars have been planted for seven to eight years surrounding the wild species *R. rugosa* and *R. multiflora*. Based on the past behavior observation of flower-visiting insects, it has been confirmed that more flower-visiting insects flock to the strongly smelling and pollen-rich *R. rugosa* and alternate between the *R. rugosa* plants, though no insect individual has been observed which moves between the wild species and the neighboring rose cultivars. In addition, based on the facts that the individuals germinated from the seeds of the planted *R. rugosa* have produced no hybrids with rose cultivars, it is considered that there is no or extremely low crossability between rose cultivars and wild species under natural conditions.

(c) Artificial crossability with wild relatives

Rose cultivars can be artificially crossed between species within the genus *Rosa*, and have been bred by artificial crossing with other species in the genus *Rosa*.

Regarding artificial inter-specific crossing, as a result of examination on the characteristics of F1 hybrid produced by artificial crossing of the dwarf *R. chinensis minima* (SIMS) Voss with Meinadentel, New Penny, Kathleen Zeimet, The Fairy, Marie Pavic, Yvonne Rabier, and Kathleen which are the cultivars belonging to Floribunda group, it is reported that the dwarf is governed by a single dominant gene (Dubois and De Vries, 1987¹⁴).

In addition, there is another report that the ever-flowering trait is governed by recessive gene based on the crossing of the Floribunda group cultivar Goldilocks with ever-flowering *R. wichuraiana* and non-everflowering *R. wichuraiana* and the backcross of Goldilocks (Semeniuk, 1971²⁶).

Moreover, there is an additional report that yellow ever-flowering cultivar is obtained from crossing of the white Hybrid Tea group cultivar White Weekend (tetraploid) with *R. foetida* cv. Autraian Briar and *R. foetida* cv. Pecian Yellow which belong to the tetraploid *R.*

foetida Herrm. (wild species native to South West Asia and Middle East Asia, producing yellow flowers, the first rose cultivar providing yellow flowers) and backcrossing of White Weekend (De Vries and Dubois, 1978¹³).

(d) The degree of apomixes causing characteristics

Rose cultivars and wild species both do not possess the characteristics to cause apomixis.

4) Production, fertility, shape, transmission method, dispersion distance and longevity of pollen

There is a wide disparity in the fertility of pollen of rose among species and cultivars, though it has been reported that the pollens of a total of 123 cultivars exhibited the germinating rates from 0% to 92.2% when they were incubated on the boric acid medium containing 50 ppm boric acid, 10% cane sugar and 1% agar at 25°C for two hours (Ueda, 1994²⁷).

In addition, in the experiment to examine to what extent the fertility of pollen is inherited to the next generation, 31 inter-cultivar hybrids have been artificially produced using 9 different Hybrid Tea group cultivars, which are different from each other in the fertility of pollen. As a result, it has been reported that there is a correlation between the measure of fertility of pollen of inter-cultivar variety (F1 hybrid) and the measure of fertility of pollen of the parent line (Visser et al., 1977²⁸).

The pollen of rose is tricolpate (containing three germ slits) with the length in the polar axis direction (major axis) ranging from approx. 30 µm to 60 µm and the width of equatorial plane (minor axis) from approx. 15 µm to 35 µm (Ueda, 1994²⁷).

Roses are insect-pollinated and the major flower-visiting insects to the genus *Rosa* include Hymenoptera, Coleoptera, and Diptera (Kevan, 2003²⁹).

The pollen of rose has the longevity of several days, and a certain measure of fertility is maintained for several days after release of pollen, though the crossing efficiency of pollen would be rapidly decreased in a few weeks of storage of pollen at ordinary temperature (Jacob and Ferrero, 2003¹⁷).

(v) Pathogenicity

(vi) Productivity of harmful substances

Cultivars of rose have been long applied for cultivation and use, but there has been no report that rose cultivars would produce any harmful substances which are likely to affect the growth or inhabitation of neighboring wild life at home in Japan and abroad.

(vii) Other information

2. Information concerning preparation of living modified organisms

(1) Information concerning donor nucleic acid

(i) Composition and origins of component elements

Composition of donor nucleic acids and origins of component elements are shown below, the relative positions between them are presented in Figure 1, and the nucleotide sequence of vector is provided in Annex 1.

a) Expression cassette for selectable marker neomycin phosphotransferase (NPT) II

Nos promoter: Nopaline synthase promoter or 5' untranslated region derived from *Agrobacterium tumefaciens*
0.3kb

NPT II coding region: Neomycin phosphotransferase (NPT) II gene derived from *E. coli (Escherichia coli)*
1.0kb

Nos 3' untranslated region: Nopaline synthase 3' untranslated region derived from *Agrobacterium tumefaciens*
0.3kb

b) Expression cassette for flavonoid 3', 5'-hydroxylase (F3'5'H)

El₂35S promoter: 35S promoter derived from cauliflower mosaic virus
0.8kb

F3'5'H coding region: Flavonoid 3',5'-hydroxylase cDNA derived from pansy (*Viola wittrockiana*)
1.8kb

Nos 3' untranslated region: Nopaline synthase 3' untranslated region derived from *Agrobacterium tumefaciens*
0.3kb

c) Expression cassette for torenia anthocyanin 5-acyltransferase (5AT)

El₂35S promoter: 35S promoter derived from cauliflower mosaic virus
0.8kb

5AT coding region: Anthocyanin 5-acyltransferase cDNA derived from *Torenia (Torenia hybrida)*
1.8kb

Nos 3' untranslated region: Nopaline synthase 3' untranslated region derived from *Agrobacterium tumefaciens*
0.3kb

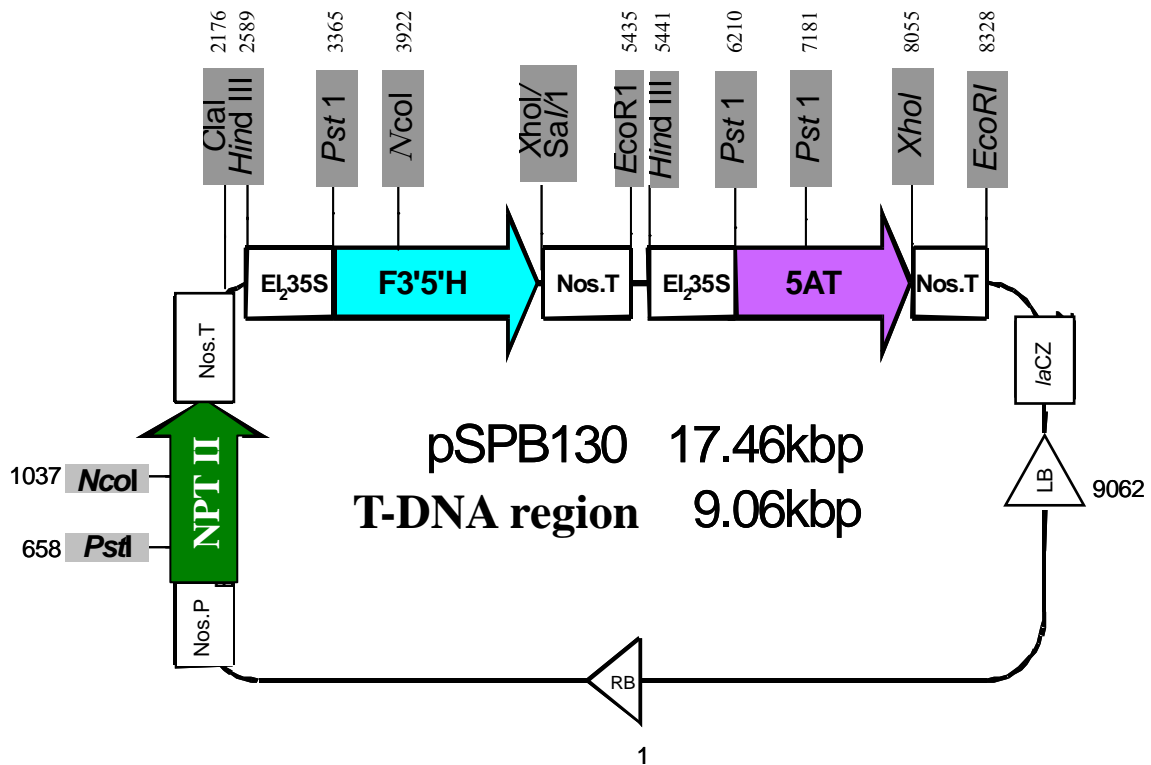

Figure 1 Structure of pSPB130

Two genes have been transferred into the binary vector pBIN19.

Nos.P: Nopaline synthase promoter or 5' untranslated region derived from *Agrobacterium tumefaciens*, NPT II: Neomycin phosphotransferase (NPT) II gene, Nos.T: Nopaline synthase 3' untranslated region derived from *Agrobacterium tumefaciens*, EL₂35S: Cauliflower mosaic virus 35S promoter, F3'5'H: Pansy flavonoid 3',5'-hydroxylase cDNA, 5AT: *Torenia* anthocyanin 5-acyltransferase cDNA.

- * The numbers provided with names of restriction enzyme represent the positions of cleavage (bp) in relation to the end of right border defined as 1.

(ii) Function of component elements

- a) Production of WKS82/130-4-1, a rose variety with modified flavonoid biosynthesis pathway

Anthocyanin constitutes a group of plant secondary metabolites generically called flavonoid, and it is a glycoside formed with a sugar component bonded to the skeletal compound (anthocyanidin). Anthocyanidin is subdivided into pelargonidin, cyanidin, and delphenidin according to the number of hydroxyl groups in the B ring. Anthocyanin causes the color of flowers to change with its different structures and thus, it becomes genetically determined based on the species or cultivar what color of flowers is obtained depending on which structure of anthocyanin is synthesized in flowers. Roses have been popular and high valued plants since antiquity as the Queen of Flowers, and a wide variety of rose cultivars have been developed through artificial crossing and breeding. Consequently, the rose cultivars of various colors including orange, yellow, red, white, and gray have been produced. However, there has been no rose cultivar providing purple to blue color flowers. This is due to the fact that roses contain no pathway in the petals for biosynthesis of purple to blue anthocyanins (delphenidin type anthocyanin) genetically by nature and then there exists no pigment.

Parts of anthocyanin biosynthesis pathway are presented in Figures 2 and 3. The anthocyanin biosynthesis pathway up to anthocyanidin 3-glucoside has been identified in the higher plants and also in roses, anthocyanin is synthesized in accordance with the pathway shown in Figure 2. In the petals of rose, anthocyanin is present mostly in the form of anthocyanidin 3,5-diglucoside and a little amount of anthocyanidin 3-glucoside is also present. In addition, the pathway shown in Figure 2 also applies to the synthesis of flavonol which is colorless by itself though helps turn the color of flowers blue by forming a complex with anthocyanin. It is also known that the pH of vacuole of petal cell can affect the flower color since anthocyanin is localized in vacuole of the cell.

The number of hydroxyl groups in the B ring in the structure of anthocyanin can greatly govern the color of flowers. The orange-red roses contain pelargonidin 3-glucoside and its derivatives which has a single hydroxyl group (only 4' is hydroxylated) in the B ring of anthocyanin, and the purple-red roses contain cyanidin 3-glucoside and its derivatives which has two hydroxyl groups (only 3' and 4' are hydroxylated) in the B ring of anthocyanin. The purple to blue roses frequently contain delphenidin 3-glucoside and its derivatives which has three hydroxyl groups (3', 4', and 5' are hydroxylated) in the B ring of anthocyanin. In addition, as the anthocyanin is modified by the aromatic acyl group, it is insusceptible to decomposition in the vacuole and thus becomes stabilized, turning the color closer to blue. The petals of rose do not contain any delphenidin 3-glucoside and its derivatives; therefore there exist no rose cultivars providing purple to blue color of flowers in the nature.

The enzymes to govern the number of hydroxyl groups in the B ring of flavonoid are flavonoid-3'-hydroxylase (F3'H) and flavonoid 3',5'-hydroxylase (F3'5'H) (Figure 3). Without the presence of both hydroxylases, pelargonidin 3,5-diglucoside accumulates, and in the presence of only F3'H, cyanidin 3,5-diglucoside accumulates. In the flowers containing F3'5'H, delphinidin is synthesized, though the petals of rose do not contain F3'5'H and thus they never accumulate in the petals. When the F3'5'H gene was transferred into the roses in which cyanidin and pelargonidin accumulate, delphinidin is produced and the color of flowers was changed, though the flower color did not turn purple-violet because the rose intrinsic metabolic pathway exists and then the produced delphinidin is mixed with cyanidin and pelargonidin.

Then, two component elements, i) to express the pansy derived F3'5'H gene in roses and ii) to express the torenia anthocyanin 5-acyltransferase gene to stabilize and make more blue the anthocyanin, were transferred into roses to accumulate delphinidin and stabilize anthocyanin and then purple-violet rose was obtained.

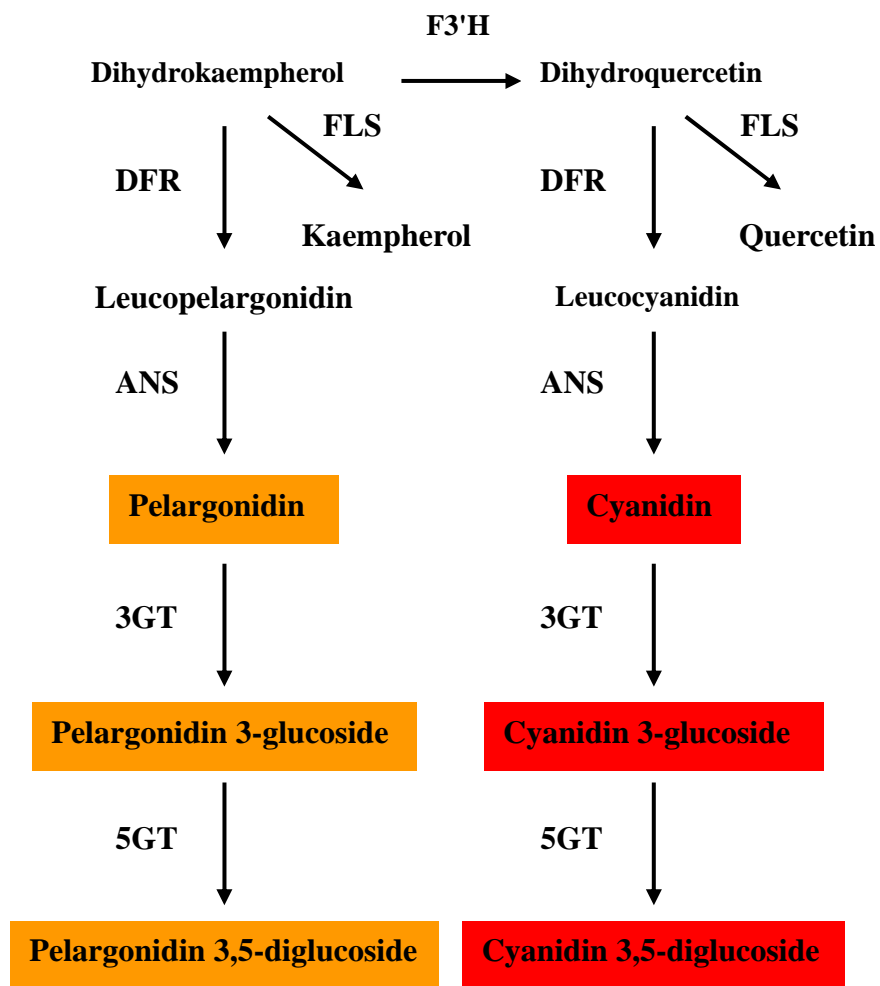

Figure 2 Outline of anthocyanin biosynthesis pathway in non-recombinant rose

In non-recombinant roses, cyanidin type anthocyanin and/or pelargonidin type anthocyanin are accumulated.

(Note) F3'H: Flavonoid-3'-hydroxylase, FLS: Flavonol synthase, DFR: Dihydroflavonol 4-reductase, ANS: Anthocyanidin synthase, 3GT: Anthocyanidin 3-glucosyl-transferase, 5GT: Anthocyanin 5-glucosyl-transferase.

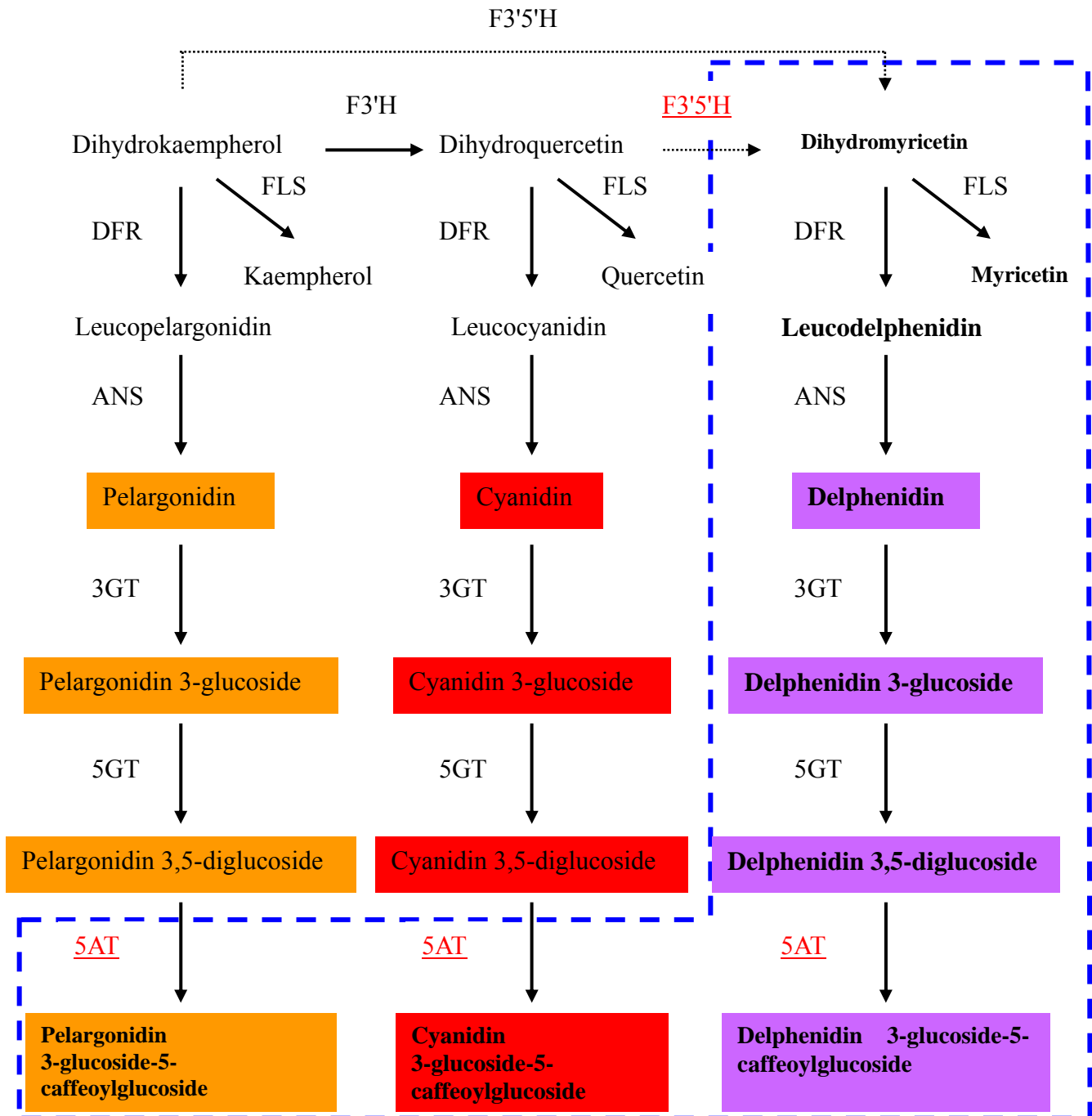

Figure 3 Outline of anthocyanin biosynthesis pathway in this recombinant rose plant

The dotted pathways do not exist in the non-recombinant roses due to the lack of F3'5'H. Transferring of the F3'5'H gene from pansy enables biosynthesis of dihydromyricetin, accumulation of bluish delphinidin type anthocyanin, and realization of blue color of flowers. In addition, transferring of the anthocyanin 5-acyltransferase (5AT) gene from torenia enables addition of aromatic acyl group to anthocyanin, stabilization of anthocyanin, and turning the anthocyanin blue.

(Note) F3'H: Flavonoid 3'-hydroxylase, F3'5'H: Flavonoid 3',5'-hydroxylase, FLS: Flavonol synthase, DFR: Dihydroflavonol 4-reductase, ANS: Anthocyanidin synthase, 3GT: Anthocyanidin 3-glucosyl-transferase, 5GT: anthocyanin 5-glucosyl-transferase, 5AT: Anthocyanin 5-acyltransferase.

* The area enclosed by the dotted box represents the pathway which is newly synthesized by the functions of the transferred genes. The transferred genes for this recombinant rose plant are underlined.

b) Function of component elements

1) Functions of individual component elements of donor nucleic acid, including target gene, expression regulatory region, localization signal, and selective marker

a. Nopaline synthase (Nos) promoter:

Promoter region from the nopaline synthase of *Agrobacterium tumefaciens*. An essential component to allow the downstream neighboring neomycin phosphotransferase (NPT) II gene to be expressed in the transgenic plant.

The nopaline synthase gene exists on the T-DNA of Ti-, Ri-plasmid. After infection of plant with *Agrobacterium*, the nopaline synthase encoded on the T-DNA of Ti or Ri plasmid assembled into the plant nuclear genome becomes expressed in the plant tumoral tissue, and the nopaline is synthesized through the reductive condensation of amino acid residue and carbonyl group of α -keto acid. The synthesized nopaline is transported by infection hypha for use as the source of carbon and nitrogen. The promoter of this nopaline synthase gene is called nos promoter, which is expressed in almost all organs in plant body (Muramatsu, 1997³⁰; Ebert et al., 1987³¹).

b. Neomycin phosphotransferase (NPT) II gene:

A drug resistance gene found by the transposon Tn5 of prokaryotic organism, encoding the neomycin phosphotransferase II. It phosphorylates kanamycin and G418 to confer the resistance against these drugs and then, it is widely used in the gene transferring experiments as a marker gene for selection of gene-transferred bacteria, yeast, plant and/or animal.

c. Nopaline synthase (Nos) gene 3' side region:

3' region of nopaline synthase gene described in above a.

d. 35S promoter:

Promoter region from cauliflower mosaic virus 35S RNA gene. An essential component to allow the downstream neighboring gene to be expressed in the transgenic plant.

The cauliflower mosaic virus possesses circular double-stranded DNA as the genome DNA and contains the gene expression-regulating site required for autonomous replicating and propagation in the nucleus of host cell by using the gene expression system of the recipient plant. The promoter for 35S RNA gene, one of the genes coded on the genome DNA, is known as 35S promoter, and it drives high levels of expression in almost every organ of plant body and at any stage of the growth and therefore, it is frequently applied for expression of foreign genes in plants. In this modification,

the El₂35S promoter is used which has enhanced the expression by repeating the enhancer site of 35S promoter (Mitsuhara et al., 1996³²).

e. Flavonoid 3',5'-hydroxylase (F3'5'H) cDNA:

Derived from pansy. It is an enzyme catalyzing the hydroxylation of the B ring of dihydroflavonols, such as converting dihydrokaempferol to dihydromyricetin, or dihydroquercetin to dihydromyricetin.

f. Anthocyanin 5-acyltransferase (5AT) cDNA:

Derived from *Torenia*. It is an enzyme acylating the glucose attached to the 5th of anthocyanidin 3,5-diglucoside to catalyze the reaction of transferring the acyl group of caffeoyl CoA or coumaroyl CoA to the glycosyl group of anthocyanin. This stabilizes the anthocyanin then makes its color more blue.

2) Functions of proteins produced by the expression of target gene and selective markers, and the fact, if applicable, that the produced protein is homologous with any protein which is known to possess any allergenicity

The F3'5'H derived from pansy converts dihydrokaempferol to dihydromyricetin, or dihydroquercetin to dihydromyricetin, and the 5TA derived from *torenia* converts delphinidin 3,5-diglucoside to delphinidin 3-glucoside-5-caffeoylglucoside. In addition, the NPT II derived from *E. coli* provides resistance to kanamycin.

As to whether or not these proteins offer homology with any protein which is known to possess any allergenicity, "Non-Food Allergen sequence" in the "Allergen sequence db" was searched using the database SWISS-PROT with the result that there was no homology identified with these proteins.

3) Contents of any change caused to the metabolic system of recipient organism

By the F3'5'H derived from pansy, dihydrokaempferol is converted to dihydromyricetin, or dihydroquercetin to dihydromyricetin. In addition, by the 5AT derived from *torenia*, delphinidin 3,5-diglucoside is converted to delphinidin 3-glucoside-5-caffeoylglucoside. Moreover, dihydromyricetin is converted to myricetin by the function of the intrinsic flavonol synthase.

(2) Information concerning vectors

(i) Name and origin

A synthetic plasmid derived from *E. coli* and *Agrobacterium*, pBIN19 (Bevan, 1984³³), was used as the vector. It contains neomycin phosphotransferase (NPT) II gene derived from *E. coli*, multi-cloning sites derived from *E. coli*, and T-DNA left border and right border sequences derived from *Agrobacterium*.

(ii) Properties

pBIN19 is a 11,777 bp binary vector, and the nucleotide sequence is provided in Annex 2.

2) Presence or absence of nucleotide sequence having specific functions, and the functions

pBIN19 represents kanamycin resistance. It contains neomycin phosphotransferase II gene (derived from *E. coli*), which gives resistance to kanamycin and used as a selectable marker, as well as T-DNA left border and right border sequences. To the plants, only the sections within the left border and right border are transferred.

3) Presence or absence of infectious characteristics of vector and the information concerning the region of recipient organism if the infectivity of vector is found present

The infectivity of this vector is not known.

(3) Method of preparing living modified organisms

(i) Structure of the entire nucleic acid transferred in the recipient organism

Outline of the structure of binary vector pSPB130 is presented in Figure 1, and the nucleotide sequence is provided in Annex 1. The binary vector pSPB130 has the approximate size of 17.46kbp, including 9.06kbp of the T-DNA region between the left border and right border. The pSPB130 was constructed by transferring the expression cassette which contains cDNA of F3'5'H gene from pansy and the expression cassette which contains cDNA of 5AT gene from torenia into the plasmid pBIN19. Therefore, the T-DNA region which is transferred to the recipient plant contains the NPT II gene to be used as the selectable marker for transgenic plant and Pansy F3'5'H gene and Torenia 5AT gene for the modification of flower color.

(ii) Method of transferring nucleic acid transferred to the recipient organism

The *Agrobacterium* method (International Publication Number: WO 2005/017147³⁴) was used for the plant transformation.

(iii) Processes of rearing of living modified organisms

This recombinant plant is raised based on the assumption that the genetransferred generation proliferates by vegetative propagation. The application for approval of this recombinant plant is intended only for the current generation of recombination.

1) Mode of selecting the cells containing the transferred nucleic acid

For selection of this recombinant plant, a selective medium containing kanamycin (50 mg/L) was used.

In September 2000, transformation was made to the recipient organism. Specifically, in the bacterial suspension of *Agrobacterium tumefaciens* Ag10 stocks (Lazo et al., 1991³⁵), callus of rose derived from the leaves of germ-free seedlings was immersed for five minutes, transferred to a medium for subculture after wiping excessive bacterial suspension off with sterile filter paper, and co-cultivated in a dark place for two days. Then, the callus was cleaned on the MS liquid medium which additionally contained 400 mg/L of carbenicillin, and transplanted onto the medium for selection and disinfection which added 50 mg/L kanamycin and 200 mg/L carbenicillin to the medium for subculture. On the selection medium, transplanting and culture were repeated for the sections which were free of growth inhibition and growing normally to select the callus resistant to kanamycin. The transformed callus showing resistance to kanamycin was cultured on the medium for regeneration, which added 50 mg/L kanamycin and 200 mg/L carbenicillin to obtain the kanamycin resistant shoots. The obtained shoots were radicated on the 1/2MS medium (without kanamycin added) and subject to conditioning. The conditioned individuals were potted then cultivated in a closed greenhouse and bloomed and then, in September 2002, this recombinant purple-violet plant was obtained. In addition, as a result of HPLC analysis, it was confirmed that delphenidin is detected from the petals of this recombinant plant. At present, the recombinant plant is maintained by vegetative propagation.

2) Presence or absence of remaining *Agrobacterium* in case of using *Agrobacterium* method for transferring nucleic acid

By applying extracts from the leaves of this recombinant plant onto the selective medium allowing *Agrobacterium* which contains the transferred gene to grow, observation was made for any growing colony to identify any residual *Agrobacterium* which contains the transferred gene. However, there was no growing colony observed (Annex 5).

Consequently, it was judged that there is no residual *Agrobacterium* which contains the transferred gene in this recombinant plant.

- 3) Processes of rearing and pedigree trees of the following lines; cells to which the nucleic acid was transferred, the line to which confirmed the state of existence of replication products of transferred nucleic acid, the line subjected to isolated field tests; and the line used for collection of other necessary information for assessment of Adverse Effect on Biological Diversity

1999 to 2000

Acquisition of recombinant plants and the first screening (selection of the plants producing delphenidin)

- WKS82/130-3-3, 3-4, 3-5, 3-6
- WKS82/130-4-1, 4-2, 4-3, 4-5, 4-6, 4-9, 4-13
- WKS82/130-5-2, 5-3, 5-6, 5-7
- WKS82/130-6-1, 6-2, 6-4, 6-9
- WKS82/130-7-3, 7-4, 7-10, 7-11
- WKS82/130-8-1
- WKS82/130-9-1, 9-2, 9-3, 9-4, 9-5, 9-6, 9-7, 9-8, 9-9, 9-10, 9-11, 9-12
- WKS82/130-10-1, 10-2, 10-4
- WKS82/130-11-1, 11-2, 11-5
- WKS82/130-12-2, 12-3



2000 to 2002

Second screening [selection of the lines allowing steady production of delphenidin at higher rate (70% or more)]

- WKS82/130-4-1, 4-2, 4-3
- WKS82/130-6-2, 6-4, 6-9
- WKS82/130-9-1, 9-3
- WKS82/130-11-5



2002 to 2003

Third screening [selection of the lines allowing steady production of delphenidin at higher rate (90% or more)]

- WKS82/130-4-1, 4-2, 4-3
- WKS82/130-9-1, 9-3



2004 to 2005

Tests in a closed greenhouse and a special screened greenhouse

- WKS82/130-4-1
- WKS82/130-9-1



2006 to 2007

Isolated field tests

- WKS82/130-4-1
- WKS82/130-9-1



2007

Application for use in general fields

- WKS82/130-4-1
- WKS82/130-9-1

* Designation of line number

Example) $\frac{\text{WKS82}}{\text{(A)}} / \frac{130}{\text{(B)}} - \frac{4}{\text{(C)}} - \frac{1}{\text{(D)}}$

(A) Name of the recipient organism

(B) Code for the transferred binary vector

(C) Number of kanamycin-resistant callus

(D) Number of kanamycin-resistant shoot obtained from the callus in (C)

(4) State of existence of nucleic acid transferred in cells and stability of expression of traits caused by the nucleic acid

(i) Place where the replication product of transferred nucleic acid exists

Regarding the presence of transferred genes (pansy F3'5'H gene, torenia 5AT gene, *E. coli* NPT II gene) in the individual organs (petals, leaves, stems, roots and pollens) of this recombinant plant, PCR analyses were carried out. As a result, signals which have expected molecular weights for the individual transferred genes were detected in the petals, leaves and stems of the recombinant plant, though no signal was detected in the pollens and roots. Consequently, it is considered that the transferred nucleic acids exist on the chromosomes of petals, leaves and stems of the recombinant plant (Annex 3).

Externally transferred nucleic acids are normally transferred onto the chromosome. In practice, however, though with extremely low probability, transferred nucleic acids may be transferred into the organellar genome of chloroplast, etc. The pansy F3'5'H gene, one of the nucleic acids transferred to the recombinant plant, intrinsically exists on the nuclear genome, and the translation product F3'5'H is translated in the cytoplasm then transferred to the endoplasmic reticulum (ER), thereby offering the intrinsic enzyme function. Assuming the F3'5'H gene is transferred to the organellar genome, the translation product cannot move from the organelle to ER and then, it is considered to fail to offer the intrinsic function. However, in this recombinant plant, delphinidin is actually produced by the function of F3'5'H which is the translation product of F3'5'H gene. This suggests that the F3'5'H gene and the other genes on the T-DNA are considered to exist on the chromosome. In addition, as a result of Southern blotting analysis, it is considered that there are several copies of transferred nucleic acid in the recombinant plant, though, based on the above understanding, it is considered that at least one of the copies exists on the nuclear genome (Annex 3). In addition, in consideration of the fact that the *Agrobacterium* method has a very low probability of transferring the genes into organellar genome, it is considered likely that the transferred nucleic acids are mostly or all present in the nuclear genome.

In addition, as a result of analysis for the layers of cell in the pedal where the transferred genes would express based on the *in situ* hybridization method, the transcript of the pansy F3'5'H gene, the transferred gene, was detected only in the layer of epidermal cell of petal (L1 layer). Consequently, it is found that in this recombinant plant, the transferred genes exist only in the L1 layer (Annex 3).

- (ii) The number of copies of replication products of transferred nucleic acid and stability of its inheritance through multiple generations

Southern blotting analyses revealed that four copies of transferred nucleic acid exist in the genome of this recombinant plant. The transferred sequence is considered to represent the entire length from LB to RB of T-DNA, or a part of the sequence from LB to RB (Annex 3).

Regarding as to whether or not the transferred genes are transmitted to the posterity (T_1 generation) obtained from artificial crossing between this recombinant plant and rose cultivars (Queen Elizabeth/Gold Bunny), PCR analyses were carried out. As a result, transferred genes derived from the recombinant plant were not detected in any individuals. This suggests that transferred genes are not transmitted to any posterity since the transferred genes do not exist in the cell of pollen of this recombinant plant (Annex 3).

Additional PCR analyses were carried out to examine whether or not the transferred genes are transferred to the posterity of self-propagation of this recombinant plant. As a result, transferred genes derived from the recombinant plant were not detected in any individuals. This suggests that transferred genes are not transmitted to any posterity since the transferred genes do not exist in the pollen and egg cell of this recombinant plant (Annex 3).

- (iii) The position relationship in the case of multiple copies existing in chromosome

It is considered that the transferred nucleic acids are located separately on the chromosome.

As a result of Southern blotting analyses, signals were detected in several fragments of relatively high polymer molecules and then it is considered that there are several copies of transferred nucleic acids. There may be a possibility that several copies of transferred genes would exist on a single fragment appearing as one signal, though there is no result obtained from the analyses on the flanking sequence of nucleic acids transferred onto chromosome, showing several copies are present adjacent to each other. Consequently, it is considered that the transferred genes are located separately.

- (iv) Inter-individual or inter-generational expression stability under a natural environment with respect to the characteristics referred to specifically in (6)-i)

Regarding the expression of transferred pansy F3'5'H gene and torenia 5AT gene in the petals, Northern blotting analyses were carried out. As a result, signals which are specific to the transferred genes and have expected molecular weight were detected only in the recombinant plants, which indicate stable expression of the

genes transferred into the genome (Annex 3). In addition, regarding the expression of transferred pansy F3'5'H gene and torenia 5AT gene in the individual organs (petals, leaves, stems) of this recombinant plant, RT-PCR analyses were carried out. As a result, it was confirmed that the transferred genes in the genomes of petals, leaves and stems are stably expressed (Annex 3).

In addition, regarding the expression stability of transferred genes in the leaves of this recombinant plant when vegetative propagation is repeated through herbaceous cutting, Northern blotting analyses were carried out. As a result, signals which are specific to the transferred genes and have expected molecular weights were detected only in the recombinant plants. Moreover, no difference was observed in the levels of expression between the samples bred by propagation by herbaceous cutting at different periods of time. Consequently, it was found that transferred genes in the genome are stably expressed even when vegetative propagation of this recombinant plant by herbaceous cutting is repeated (Annex 3). In fact, the color of flowers obtained from the expression of the transferred genes is a stable purple-violet in this recombinant plant, and there is no case reported referring to occurrence of any flower color other than purple-violet in the cultivation from both cutting and grafting.

Consequently, in this recombinant plant, stable expression of the genes transferred into the genome is expected.

The commercial cultivation of roses has been focusing on cultivation through grafting chiefly using the wild species of genus *Rosa* as rootstock for the growth promotion purposes. Also in the commercial cultivation of this recombinant plant after obtaining the approval, cultivation through grafting is scheduled using this recombinant plant as scion and the genus *Rosa* (*Rosa multiflora*, *Rosa odorata*, *Rosa canina*, *Rosa 'Natal Briar'*, *Rosa 'Dr. Huey'*, etc.) as rootstock. Cultivation through grafting is known to involve transfer of various materials between scion and rootstock, this is expected true also for the cultivation of this recombinant plant through grafting.

Possible effects of scion on rootstock include expected transfer of transcription products derived from the genes transferred to this recombinant plant, proteins and newly generated pigments to the rootstock. However, the transcription products from the transferred genes to this recombinant plant are localized only in the L1 layer (Annex 3), and the localization is maintained even in the individuals which are different from each other in the growth period and cultivation site. In addition, when proteins migrate between cells, they possess the signal sequences for secretion to the outside of cells in general. However, as a result of searching using the PSORT (<http://psort.nibb.ac.jp/>), there was no such sequence identified in any of the proteins produced by the transferred genes. Moreover, delphinidin and other flavonoid-based pigments produced newly in the cells as a result of expression of transferred genes are accumulated in the vacuole in the cell (Koseki et al., 2004³⁸). Based on the above understanding, the possibility is found extremely low that the products from the transferred genes to this recombinant plant would migrate to the rootstock in the cultivation through grafting, and even in the case of grafting this recombinant plant, it is considered less unlikely that Adverse Effect on Biological Diversity could arise compared to the case of grafting

the recipient organism.

In addition to the transfer of materials from scion to rootstock, transfer of various materials from rootstock to scion could occur. In the cultivation of roses through grafting, chiefly wild species of genus *Rosa* are used as rootstock, though rose cultivars have been produced by artificial crossing between wild species. This means that the cultivation of roses through grafting uses the species which are extremely close to each other as scion and rootstock. In the roses, it is generally known that with promotion of growth through grafting, the length of cut flowers and available number of flowers are increased. In actuality, there are many cases reported that these characteristics have been improved in a variety of rose cultivars due to the cultivation through grafting (Okawa, 1999³⁹). However, though the cultivation of roses through grafting has a long history of over 350 years, there has been no report referring to the changes in characteristics exceeding the extent of quality improvement as cut flowers, e.g., dramatic changes in flower color and/or flowering period and in fact, there is no case in which the genetic characters of scion have been changed by grafting. Therefore, it is considered extremely low that even grafting of this recombinant plant on any rootstock of related species would cause such interaction with the rootstock that exceeds the extent of quality improvement for cut flowers not seen in the grafting of recipient organism by the transferred genes due to transfer of materials from the rootstock.

In addition, the viability of scion in the cultivation through grafting depends on a combination of scion and rootstock, though the viability of grafted rose stocks reportedly varies according to the intrinsic viability of the cultivar used as scion provided that grafting is conducted on the same rootstock (de Vries, 2003³⁷). In the special screened greenhouse tests and isolated field tests, examination was made for growth between recipient organism and recombinant plant in the cultivation through herbaceous cutting with the result that there was few difference (Annex 5, Annex 6). This leads to the estimation that cultivation of recipient organism and recombinant plant through grafting using the same rootstock would cause no difference in the viability of scion. Therefore, in the cultivation through herbaceous cutting using the scion root, no difference was observed in the Adverse Effect on Biological Diversity between recipient organism and this recombinant plant and then, it is also considered that no difference would be observed in the Adverse Effect on Biological Diversity between recipient organism and this recombinant plant even in the cultivation through grafting.

In addition, due to the indefinite buds produced at the joining area between scion and rootstock from grafting, graft hybrids can occur containing the cells from the both plants. However, in order to obtain graft hybrids in general, such artificial treatment is necessary as cutting off the joining area after grafting and facilitating the forming of indefinite buds. Even in this case, it is known that the probability of availability of graft chimera is extremely low. Moreover, based on the facts that in the woody plants including roses, the ability of producing indefinite buds is low and that production of indefinite buds in the joining area is rare in the typical cultivation through grafting, it is considered extremely low that graft hybrids would occur even in the cultivation through grafting. Even if graft hybrids occur, the hybridism never be transmitted to the next generation, so it is considered extremely low that graft hybrids could proliferate under natural conditions and in the typical

cultivation through grafting.

Should any graft hybrids be detected in the cultivation of this recombinant plant through grafting, the grafted stocks will be surely inactivated by incineration and/or plow-in.

Based on the above understanding, it is considered that cultivation of this recombinant plant through grafting will provide similar Adverse Effect on Biological Diversity as in the cultivation through herbaceous cutting.

- (v) Presence or absence, and if present, degree of transmission of nucleic acid transferred through virus infection and/or other routes to wild animals and wild plants

(5) Methods of detection and identification of living modified organisms and their sensitivity and reliability

The genome sequence in the neighboring regions of T-DNA transferred in the genome of this recombinant plant was identified. Based on the sequence information, PCR primer was prepared and then with the PCR method using the primer, the conditions allowing detection and identification specifically for this recombinant plant were determined. In addition, this method was confirmed to allow detection of this recombinant plant by using the genome DNA of 10 ng at a minimum for reaction.

Methods of detection and identification of living modified organisms—See Annex 4.

Their sensitivity and reliability

—See Annex 4.

(6) Difference from the recipient organism or the species to which the recipient organism belongs

- (i) Specific contents of physiological or ecological characteristics that were accompanied by the expression of replication products of transferred nucleic acid

By transferring pansy F3'5'H gene and torenia 5AT gene to the recipient organism, delphinidin 3-glucoside-5-caffeoylglucoside was produced and the flower color changed to purple-violet.

- (ii) With respect to the physiological or ecological characteristics listed below, presence or absence of difference between genetically modified agricultural products and the taxonomic species to which the recipient organism belongs, and the degree of difference, if present

These were evaluated based on the data from the tests carried out in the closed greenhouse and special screened greenhouse which are located inside Suntory Limited in 2004 to 2005, the tests carried out in the special screened greenhouse which is located in the Misaki field of Nihon-Shokusei Co., and the tests carried out

in the isolated field which is located in the Misaki field of Nihon-Shokusei Co. in 2006 to 2007.

(a) Morphological and growth characteristics

The recipient organism and the recombinant plant were cultivated in a special screened greenhouse to identify the growth characteristics, i.e., plant height, number of nodes, and flowering time, the morphological characteristics, i.e., diameter of flower, number of petals, number of anthers, length of anther, and width of anther, and the other characteristics about fragrance of flower. In the number of petals among the items examined, a statistically significant difference (Student *t* test, level of significance 5%) was observed between the recipient organism and the recombinant plant. Specifically, in the special screened greenhouse, the number of petals was 33.2 ± 7.1 on average for the recipient organism compared to 25.2 ± 2.9 on average for the recombinant plant.

For plant height, number of nodes, flowering time, diameter of flower, number of anthers, length of anther, width of anther, and fragrance of flower, no difference was observed between the recipient organism and the recombinant plant (Annex 5).

In addition, the recipient organism and the recombinant plant were cultivated in an isolated field (vinyl greenhouses and outdoors) to identify the similar items as described above. In the number of petals, a statistically significant difference (Student *t* test, level of significance 5%) was observed between the recipient organism and the recombinant plant. Specifically, in the vinyl greenhouse C, the number of petals was 32.6 ± 6.8 on average for the recipient organism compared to 25.9 ± 3.7 on average for the recombinant plant. In the outdoors A, the number of petals was 32.8 ± 6.1 on average for the recipient organism compared to 23.9 ± 3.9 on average for the recombinant plant.

For plant height, number of nodes, flowering time, diameter of flower, number of anthers, length of anther, width of anther, and fragrance of flower, no difference was observed between the recipient organism and the recombinant plant (Annex 6).

(b) Cold-tolerance and heat-tolerance at the early stage of growth

Seedlings of the recipient organism and the recombinant plant were cultivated in a climate chamber maintained at low or high temperatures for one month to identify the growth rate at the stage of bud. As a result, in the both conditions, low temperature (5°C) and high temperature (35°C), no difference was observed in the growth rate between the recipient organism and the recombinant plant (Annex 5).

(c) Wintering ability and summer survival of the matured plant

As a result of examination on the wintering ability and summer survival of the

matured plant, all the plants examined could overwinter and survived the summer and no difference was observed between the recipient organism and the recombinant plant (Annex 6).

(d) Fertility and size of the pollen

In both plants of the recipient organism and the recombinant plant cultivated in a special screened greenhouse, existence of pollen was confirmed. There was no statistically significant difference in the degree of mature of pollen and the rate of germination of pollen between the recipient organism and the recombinant plant (Annex 5).

Also for the size of pollen, no statistically significant difference (Student *t* test, level of significance 5%) was observed between the recipient organism and the recombinant plant, and no difference was observed in the shape of pollen between the both plants (Annex 5).

In both plants of the recipient organism and the recombinant plant cultivated in an isolated field (vinyl greenhouse and outdoors), existence of pollen was confirmed. There was no statistically significant difference in the degree of mature of pollen and the rate of germination of pollen between the recipient organism and the recombinant plant (Annex 6).

Also for the size of pollen, no statistically significant difference (Student *t* test, level of significance 5%) was observed between the recipient organism and the recombinant plant, and no difference was observed in the shape of pollen (Annex 6).

(e) Production, shedding habit, dormancy and germination rate of the seed

For the recipient organism and the recombinant plant cultivated in the isolated field (vinyl greenhouse and outdoors), the opened flowers were left to stand and observed for about two months to identify whether or not fruits are borne and seeds are set. As a result, fruit bearing and seed setting were not identified in both plants of the recipient organism and the recombinant plant (Annex 6).

Therefore, production, dormancy and germination rate of the seed have not been investigated.

(f) Crossability

Pollens existed in both of the recipient organism and recombinant plant cultivated in both special screened greenhouse and isolated field and their maturing and germinating ability were confirmed, though no difference was observed between the recipient organism and the recombinant plant (Annex 5, Annex 6).

In the tests carried out in a special screened greenhouse, crossability of the recipient organism and the recombinant plant with rose cultivars (Queen

Elizabeth, Gold Bunny) was examined based on artificial crossing. As a result, almost no difference was observed in the rate of fruit bearing between the recipient organism and the recombinant plant. In addition, the posterity obtained from a cross with the recombinant plant was examined, though no transferred gene from the recombinant plant was detected in the individual plants (Annex 5).

Crossability of the recipient organism and the recombinant plant with wild species (*R. multiflora*) was examined based on artificial crossing. As a result, fruit bearing was slightly confirmed in both cases when the recipient organism and the recombinant plant were used as the pollen parent. However, as a result of PCR analyses on the obtained seeds, no transferred gene from the recombinant plant was detected, and the obtained seeds were the seeds of self-propagation of *R. multiflora* or the transferred genes were not contained in the cell of pollen of the recombinant plant though the cross-pollination occurred. For these reasons, it was indicated that the transferred genes were not transmitted to posterity (Annex 5).

Crossability of the recipient organism and the recombinant plant with wild species (*R. multiflora*) was examined by releasing bees. As a result, fruit bearing was slightly confirmed in both cases when the recipient organism and the recombinant plant were used as the pollen parent. However, as a result of PCR analyses on the obtained seeds, no transferred gene from the recombinant plant was detected, and the obtained seeds were the seeds of self-propagation of *R. multiflora* or the transferred genes were not contained in the cell of pollen of the recombinant plant though the cross-pollination occurred. For these reasons, it was indicated that the transferred genes were not transmitted to posterity. In addition, as a result of behavior observation of *Bombus ignites*, the bees concentratedly flock to the flowers of *R. multiflora* with strong smell and smaller number of petals, and there was almost no individual which alternates between the flowers of the recipient organism or the recombinant plant and the flowers of *R. multiflora*, though bees come and go between the flowers of *R. multiflora* (Annex 5).

Pollens were confirmed in both of the recipient organism and recombinant plants, though as a result of examination on the dispersion of pollens by air blowing, no dispersion of pollens from the recipient organism and the recombinant plant was identified (Annex 5).

In the isolated field tests, crossability of the recipient organism and the recombinant plant with rose cultivars (Queen Elizabeth, Gold Bunny) was identified by artificial crossing. As a result, almost no difference was observed between the recipient organism and the recombinant plant regarding the rate of fruit bearing. In addition, as a result of analyses on the posterity obtained from a cross with the recombinant plant, no transferred gene from the recombinant plant was detected in the obtained seedlings and seeds (Annex 6).

Crossability of the recipient organism and the diploid form of recombinant plant with the wild species (*R. multiflora*, *R. wichuraiana*, *R. rugosa*) was identified by artificial crossing. As a result, fruit bearing was slightly

confirmed in both cases when the recipient organism and the recombinant plant were used as the pollen parent. The seeds were collected, treated at low temperatures and then sown, and only a part of the seeds became germinated. The obtained seedlings were subjected to PCR analyses with the result that hybrids with the recipient organism or the recombinant plant were confirmed, though no transferred gene from the recombinant plant was detected. Moreover, the seeds sown but not germinated were collected to identify the maturing of seeds. As a result, most of the seeds were found "empty (without any contents in the seeds)" and only a few seeds were found to contain the normal embryo. These seeds were subjected to PCR analysis with the result that crossing with the recipient organism or the recombinant plant was confirmed though no transferred gene from the recombinant plant was detected. As for the *R. wichuraiana*, no normal embryo was confirmed from all the seeds (Annex 6).

Furthermore, crossability of the recipient organism and the tetraploid form of recombinant plant with the wild species (*R. acicularis*) was identified by artificial crossing. As a result, no fruit bearing was confirmed in both cases when the recipient organism and the recombinant plant were used as the pollen parent (Annex 6).

In an isolated field, the wild species (*Rosa multiflora*) was planted 1 m and 5 m distant from the recipient organism or the recombinant plant to identify crossability with wild species under natural conditions. As a result, in the seedlings obtained from the seeds collected from the both sites, crossability with the recipient organism or the recombinant plant was not confirmed, and no transferred gene from the recombinant plant was detected (Annex 6).

(g) Productivity of harmful substances

Cultivars of rose have long been cultivated and used, though there has been no report that rose cultivars would produce any substances which affect growth or inhabitation of surrounding wild animals and wild plants both at home and abroad. In addition, in order to identify the possibility that the transferred gene could affect the metabolism of the recombinant plant and cause productivity of any harmful substance, a plow-in test and succeeding crop test were carried out for any effect on germination of lettuce seeds.

In the tests carried out in a special screened greenhouse, no statistically significant difference was observed between the recipient organism and the recombinant plant (Annex 5). In addition, also in the isolated field tests, no statistically significant difference was observed between the recipient organism and the recombinant plant (Annex 6).

Moreover, as a result of soil microflora test, as well as special screened greenhouse test and isolated field test, no statistically significant difference was observed in the number of bacteria, filamentous fungi, and actinomycetes between the recipient organism and the recombinant plant (Annex 5, Annex 6).

II. Review by persons with specialized knowledge and experience concerning Adverse Effect on Biological Diversity

A review was made by persons with specialized knowledge and experience concerning Adverse Effect on Biological Diversity (called Experts) for possible Adverse Effect on Biological Diversity caused by the use in accordance with the Type 1 Use Regulation for Living Modified Organism based on the “Law concerning the Conservation and Sustainable Use of Biological Diversity through Regulations on the Use of Living Modified Organisms.” Results of the review are listed below.

1. Item-by-item assessment of Adverse Effect on Biological Diversity

(1) Competitiveness

Rose (*Rosa hybrida*, hereinafter referred to as “rose cultivar”) to which the recipient organism belongs has been long cultivated in Japan, though there is no report that rose cultivar is wild growing in a natural environment.

This recombinant cultivar of rose produces delphinidin and myricetin, which are the anthocyanin showing blue to purple colors, in the petals and leaves as a result of expression of the transferred genes. In the tests carried out in special screened greenhouses and isolated fields, a significant difference was observed in the number of petals between the recipient organism and the recombinant plant, though no difference was observed between the both plants regarding the other morphological and growth characteristics. In addition, it is considered unlikely that the productivity of delphinidin and myricetin would be a dominant trait in competitiveness.

In this recombinant cultivar of rose, the color of flowers has changed due to the purple-violet pigment accumulated in the petals, though there has been no report that in the rose cultivars of various flower colors developed based on cross breeding, changes in flower color have caused changed in the flower-visiting insect fauna. As a result of examination on the flower-visiting insect fauna carried out in an isolated field, it was found that the changed flower color to purple-violet in this recombinant cultivar of rose has almost never affected the number and variety of flower-visiting insects. Furthermore, fragrance is also an important element for flower-visiting behavior, though, as a result of analysis, no difference was observed between the recipient organism and the recombinant plant.

Based on the above understanding, the following conclusion by the applicant was judged reasonable: There are no wild animals or plants identified which may be subjected to the effects attributable to Type 1 Use of this recombinant cultivar of rose, and there is no risk of Adverse Effect on Biological Diversity caused by the competitiveness.

(2) Productivity of harmful substances

There is no report that the rose cultivar to which the recipient organism belongs produces any substances which could affect growth or inhabitation of surrounding wild animals and wild plants.

This recombinant cultivar of rose produces delphenidin and myricetin, though the delphenidin and myricetin has not been reported as harmful substances. In addition, in isolated fields, this recombinant cultivar of rose has been investigated for productivity of any harmful substances (the substances secreted from the roots which can affect other plants, the substances secreted from the roots which can affect microorganisms in soil, and the substances existing in the plant body which can affect other plants after dying) in a series of tests of succeeding crop, soil microflora and plow-in with the result that there is no significant difference observed from the recipient organism in all the tests.

The F3'5'H protein and the 5AT protein have been confirmed not to have any homology with any known allergens as a result of searching for homology in terms of amino acid sequence.

Based on the above understanding, the following conclusion by the applicant was judged reasonable: There are no wild animals or plants identified which may be subjected to the effects attributable to Type 1 Use of this recombinant cultivar of rose, and there is no risk of Adverse Effect on Biological Diversity caused by the productivity of harmful substances.

(3) Crossability

(i) Identification of wildlife likely to be affected

Rose cultivar can cross with related wild species of genus *Rosa* (hereinafter referred to as "wild species"). Ten species and six variant species have been identified as the wild plants which can cross with the recombinant cultivar of rose in Japan.

(ii) Evaluation of concrete details of adverse effect

When this recombinant cultivar of rose crosses with the wild species identified above, there are possibilities that the hybrids may be replaced by the wild species, the nucleic acid transferred to this recombinant plant is transmitted to the wild species and the flavonoid biosynthesis pathway is modified then the flower color, leaf color and various traits relating to stress resistance in the wild species may be changed.

(iii) Evaluation of likelihood of adverse effect

The possibility of crossing of this recombinant cultivar of rose cultivated in isolated fields with the wild species identified above cannot be denied. However, based on the facts listed below, it is considered very unlikely that this recombinant cultivar of rose crosses with the wild species and fruits are borne.

- a. As a result of identification of crossability by artificial crossing, regarding the rate of fruit bearing due to crossing between rose cultivar and wild species, there was almost no difference between this recombinant plant and the non-recombinant plant.
- b. In the tests of artificial crossing with *R. acicularis*, the tetraploid form of wild species, which is growing wild in Japan and has the same polyploidy as the

rose cultivar, no fruit bearing was confirmed in either case when the recipient organism or the recombinant plant was used as the pollen parent.

- c. As a result of examination for crossability under a natural condition by planting *R. multiflora* at distances of 1 m and 5 m, crossing between the recipient organism and the recombinant plant was not confirmed and the transferred gene from the recombinant plant was not detected.
- d. In the monitoring survey, within a range of 500 m from an isolated field, crossability of wild species growing wild with rose cultivar was investigated. As a result, no crossing with rose cultivar was identified in all of approx. 1,800 seeds examined.

This recombinant plant has been indicated to be a chimera plant in which the transferred genes are not detected from pollens and egg cells. Even if the chimera is dissolved for any reasons, since it is very unlikely that rose cultivars cross-hybridize with wild rose species, it is considered very unlikely that the transferred genes do not remain in the group of wild species at lower rates but proliferate under a natural environment in Japan.

2. Conclusion based on the Biological Diversity Risk Assessment Report

Based on the above understanding, the Biological Diversity Risk Assessment Report concluded that there is no risk that the use of this recombinant rose in accordance with Type 1 Use Regulation causes Adverse Effect on Biological Diversity. It was judged that the conclusion above made by the applicant is reasonable.

Reference

- 1) Yotaro Tsukamoto, An Encyclopedia of Garden Plants Vol. 4, Shogakukan Inc., 14-15, 20-43, 1989
- 2) Yoshihiro Ueda, An Encyclopedia of Flower Gardening 10 Rose, Rural Culture Association, 3-11, 2002
- 3) Yoshihiro Sakanishi, An Encyclopedia of Garden Plants Vol. 4, Shogakukan Inc., 33, 1989
- 4) Isamu Hayashi, An Encyclopedia of Flower Gardening 10 Rose, Rural Culture Association, 12-19, 2002
- 5) Hisao Tsurushima, Floricultural Science Handbook, Yokendo Co., Ltd., 630-646, 1979
- 6) Kiyoshi Okawa, An Encyclopedia of Garden Plants Vol. 4, Shogakukan Inc., 34, 1989
- 7) Kiyoshi Okawa, An Encyclopedia of Flower Gardening 10 Rose, Rural Culture Association, 51-54, 2002
- 8) Yoshinori Kano, An Encyclopedia of Flower Gardening 10 Rose, Rural Culture Association, 37-43, 2002
- 9) Tatsushi Kondo, Weekly Flower Encyclopedia, Rose 1, Kodansha Ltd., 4-20, 2004
- 10) Kazuko Nomura, Old Rose Flower Picture Book, Shogakukan Inc., 8-21, 143-157, 2004
- 11) Kozo Sakai, An Encyclopedia of Flower Gardening 10 Rose, Rural Culture Association, 59-63, 2002
- 12) Gudin, S., Seed propagation., Encyclopedia of rose science, 620-623, 2003
- 13) De Vries, D. P., Dubois, L. A. M., On the transmission of the yellow flower colour from *Rosa foetida* to recurrent flowering hybrid tea-roses., Euphytica 27: 205-210, 1978
- 14) Dubois, L. A. M., De Vries, D. P., On the inheritance of the dwarf character in polyantha x *Rosa chinensis minima* (SIMS) Voss F1-populations., Euphytica 36:535-539, 1987
- 15) De Vries, D. P., Dubois, L. A. M., Pollen and pollination experiments. X. the effect of repeated pollination on fruit- and seed set in crosses between the hybrid tea-rose cvs. Sonia and Ilona., Euphytica 32:685-689, 1983
- 16) Ueda, Y., Akimoto, S., Cross- and self-compatibility in various species of the genus *Rosa*, J. of Horticultural Science and Biotechnology, 76:392-395, 2001
- 17) Jacob, Y., Ferrero, F., Pollen grains and tubes., Encyclopedia of rose science, 518-523, 2003

- 18) Gudin, S., Rose:Genetics and Breeding., Plant Breeding Reviews, 17:159-189, 2000
- 19) Hurst, C. C., Notes on the origin and evolution of our garden roses, J. of Royal Horticultural Society, 66:73-82, 1941a
- 20) Hurst, C. C., Notes on the origin and evolution of our garden roses, J. of Royal Horticultural Society, 66:242-250, 1941b
- 21) Hurst, C. C., Notes on the origin and evolution of our garden roses, J. of Royal Horticultural Society, 66:282-289, 1941c
- 22) Wylie, A. P., The history of garden roses, Part I., J. Royal Hort. Soc. 79:555-571, 1954
- 23) Wylie, A. P., The history of garden roses, Part II., J. Royal Hort. Soc. 79:8-24, 1955a
- 24) Wylie, A. P., The history of garden roses, Part III., J. Royal Hort. Soc. 80:77-87, 1955b
- 25) Noriko Nakamura, Masako Mizutani, Yoishiie Matsuda, Shunsuke Takeuchi, Keiji Furuichi, Mitsue Yoshimoto, Akihiro Matsunaga, and Yoshikazu Tanaka, Crossability between cultivar roses and wild roses under natural conditions, Horticultural Research (Japan) Vol. 6 Supplement 1, Syllabus of FY 2007 The Japanese Society for Horticultural Science Spring Meeting for the Presentation of Research Papers, 506, 2007
- 26) Semeniuk, P., Inheritance of recurrent and nonrecurrent blooming in 'Goldilocks' X *Rosa wichuraiana* progeny., J. of Heredity, 62:319-320, 1971
- 27) Yoshihiro Ueda, Taxonomic Research on Plants of the Genus Rosa, Faculty of Horticulture, Chiba University Scientific Report, 48:241-328, 1994
- 28) Visser, T., De Vries, D. P., Scheurink J. A. M., Welles G. W. H., Hybrid tea-rose pollen. II. Inheritance of pollen viability., Euphytica, 26:729-732, 1977
- 29) Kevan, P. G., Pollination., Encyclopedia of rose science, 456-460, 2003
- 30) Masami Muramatsu, Molecular and Cellular Bioscience Dictionary, Tokyo Kagaku Dojin Co., Ltd., 155, 1997
- 31) Ebert, P. R., Ha, S.B., An, G., Identification of an essential upstream element in the nopaline synthase promoter by stable and transient assays., Proc. Natl. Acad. Sci. USA 84:5745-5749, 1987
- 32) Mitsuhashi, I., Ugaki, M., Hirochika, H., Ohshima, M., Murakami, T., Gotoh, Y., Katayose, Y., Nakamura, S., Honkura, R., Nishimiya, S., Ueno, K., Mochizuki, A., Tanimoto, H., Tsugawa, H., Otsuki, Y., Ohashi, Y., Efficient promoter cassettes for enhanced expression of foreign genes in dicotyledonous and monocotyledonous plants., Plant Cell Physiol. 37:49-59, 1996

- 33) Bevan, M., Binary *Agrobacterium* vectors for plant transformation., *Nucleic Acids Res.* 12:8711–8723, 1984
- 34) Tanaka, Y., Fukui, Y., Togami, J., Katsumoto, Y., Mizutani, M., PROCESS FOR PRODUCING ROSE WITH MODIFIED COLOR.,PCT/JP2004/011958,WO 2005/017147
- 35) Lazo, G. R., Stein, P. A., Ludwig R. A., A DNA transformation–competent *Arabidopsis* genomic library in *Agrobacterium*., *Biotechnology* 9: 963-967, 1991
- 36) Huala, E., Sussex, I. M., Determination and cell interactions in reproductive meristems., *Plant Cell* 5: 1157-1165, 1993
- 37) de Vries, P.D., Scion-Rootstock Relationships in Cut Roses., *Encyclopedia of rose science*, 634-635, 2003
- 38) Yoshihiro Koseki, Nobuhiro Sasaki, Yozo Yagira, Hiroshi Abe, and Yoshio Ito, Approaches to Plant Pigments, Osaka Municipal Universities Press (OMUP), 119-130, 2004
- 39) Kiyoshi Okawa, Production Engineering and Physical Distribution of Roses, Yokendo Co., Ltd., 63-70, 1999